

PAF[®]

Power Assisted Fuse

For Systems rated 2.8-38kV and continuous currents up to 600A.



- Indoor or outdoor application
- Easy to install and maintain
- Laboratory and field tested
- Professional G&W support
- Current limiting
- Arc Flash reduction
- Network Protection
- Cost effective

G&W Engineered to order. Built to last.

Catalog C-paf17

G&W's Power Assisted Fuse (PAF)® offers current limitation to systems with continuous current ratings through 600A and up to 38kV. This makes the PAF ideal for applications beyond the ratings of conventional current limiting fuses and for economical alternatives to conventional expulsion, vacuum and SF6 fuses which are not current limiting.

The PAF is a commutating form of current limiting device where the continuous current is carried by a continuous copper bus bar path. This path is opened under overcurrent conditions to transfer current to a parallel mounted current limiting fuse.

The PAF can be mounted indoors or out. Metal enclosed PAF fuses are available with enclosures, cable terminations, bus connections, supports and enclosures.

NEED FOR IMPROVED PROTECTION

With the ever increasing demand for electrical energy, distribution systems have been forced to expand and grow. Stiffened transmission systems, increased substation capacity and on-site generation all contribute to subsequent increases in available fault currents imposed on equipment. This short circuit current, if uncontrolled, can exceed the thermal and mechanical capability of electrical devices on the system, severely damaging equipment and thus jeopardizing power supply.

CONVENTIONAL FAULT INTERRUPTING DEVICES

Traditionally, the current limiting fuse has worked well as overcurrent protection on systems with normal continuous currents up to 200A. Their current limitation capability, speed of operation, compact size and low cost make them ideal add-ons to existing installations. Current limitation is a major benefit because it yields a significant reduction in the magnitude of the let-through current. This can lead to substantial sav-

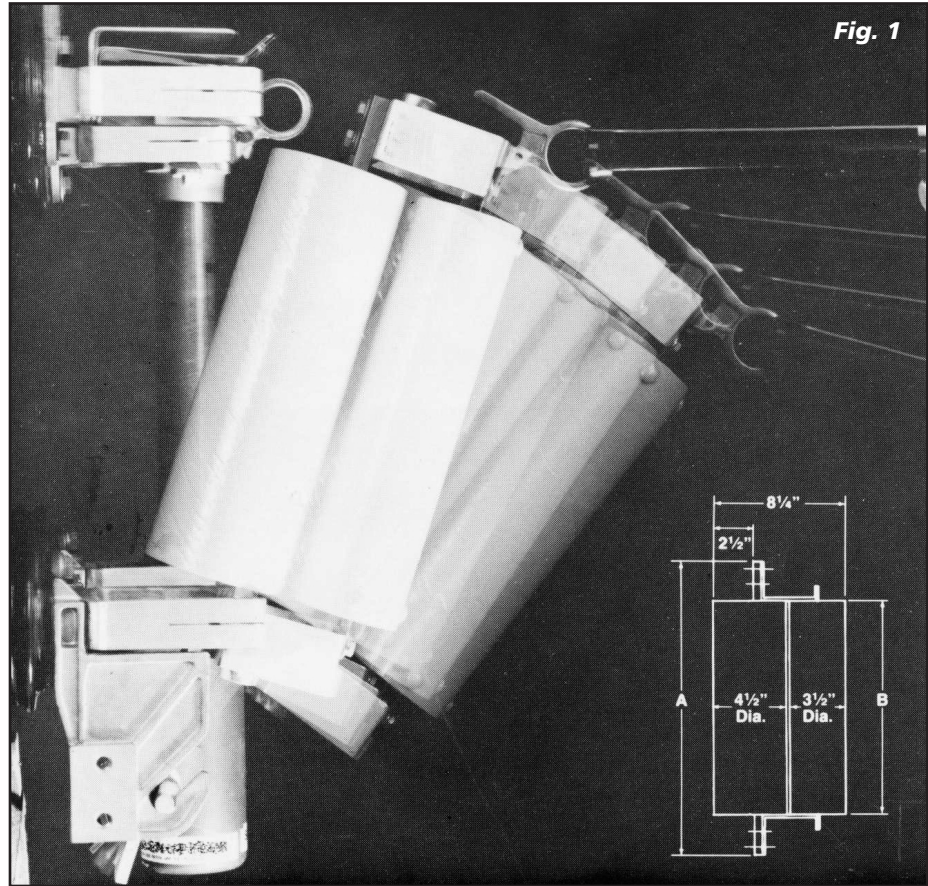

Fig. 1

▲ G&W's PAF can be specified to fit within a conventional power fuseholder.

ings by reducing damage to the faulted equipment. The energy limiting capabilities of current limiting fuses may prevent the secondary catastrophic failures and effective arc flash/blast reduction.

For systems rated above 200A, circuit breakers and explosion fuses are most commonly used. Though able to withstand higher continuous current, these devices are not current limiting and are relatively slow interrupters, therefore permitting the damage of higher let-through currents to occur. The application of a PAF for protection of underrated switchgear can provide significantly improved protection at a substantial cost savings over replacement of that switchgear. Also, for applications where available fault currents have increased due to expanding power requirements, simply replacing the circuit breakers may not be adequate protection for other underrated equipment on the system.

PAF OPERATION

A large cross section copper conductor carries the continuous current. Upon occurrence of a short circuit current, a sensing element initiates triggering of a cutting device placed at strategic intervals along the copper bus. This creates multiple gaps in the bus. The cutting devices are similar to those that have been developed for military and space applications in which long shelf life and reliable operation are prime requirements.

The arc voltage across the gaps forces the short circuit current to a parallel mounted current limiting fuse. The fuse element melts in the conventional manner, interrupting the current without venting of flames or gases.

At short circuit current levels, current limitation is provided within the first half loop of fault current and prior to the first current peak.

ELECTRICAL RATINGS

Voltage Class (kV)	2.8 - 38kV*
Continuous Current (A, rms, sym)	200A-600A
Interrupting Rating (A, rms, sym)	40,000 60,000*
Current peak let-through, @40kA rms sym	20,000

* Optional- consult factory

MECHANICAL RATINGS

For typical 15.5kV units (see Fig. 1)	
Length "A" inches (mm)	18.5 (470)
Length "B" inches (mm)	13.5 (343)
Minimum phase-to-phase spacing (C/L - C/L), inches (mm)	15 (381)
Total installed weight per phase, for fuse holder mounting, lbs. (kg)	28 (12.7)
Weight per interrupter fuse combination, lbs (kg)	22 (10)

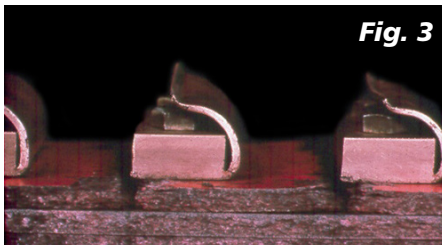

Fig. 3

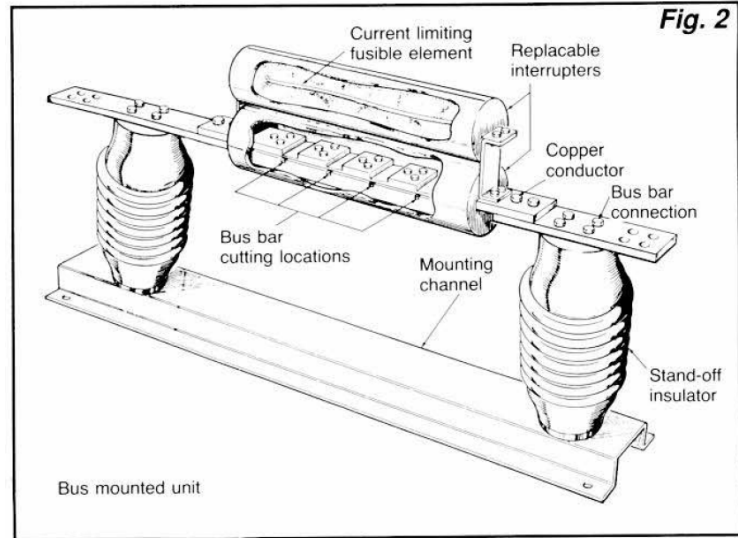

Fig. 2

OPERATION SEQUENCE

Refer to copy

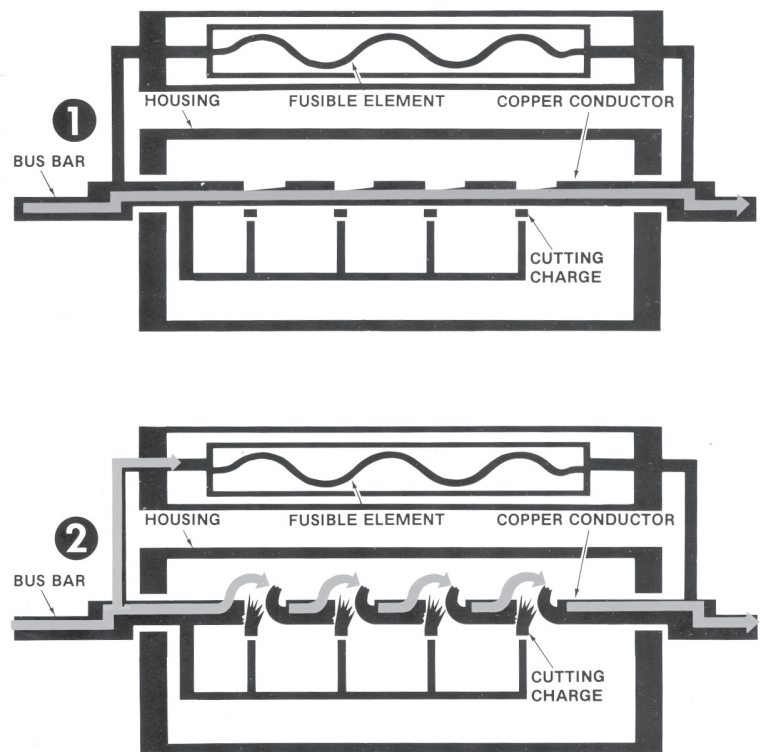

Fig. 4

Voltage Class Max. (kV)	Catalog Number			
	Continuous Current (Max.)			
	200A	300A	400A	600A
2.8kV (60kV BIL)	2PAF200	2PAF300	2PAF400	2PAF600
5.5kV (60kV BIL)	5PAF200	5PAF300	5PAF400	5PAF600
8.3kV (110kV BIL)	8PAF200	8PAF300	8PAF400	8PAF600
15.5kV (110kV BIL)	15PAF200	15PAF300	15PAF400	15PAF600
27kV (150kV BIL)	27PAF200	27PAF300	27PAF400	27PAF600
38kV (200kV BIL)	38PAF200	38PAF300	38PAF400	38PAF600

ORDERING INFORMATION

The following information is required at the time of order placement:

1. System operating voltage.
2. Continuous current
3. Prospective rms, symmetrical fault current.
4. Rating of the protected equipment or the desired limits.
5. Magnitudes of current inrushes to motors, capacitor banks etc.
6. Type of mount, non-loadbreak switch or bolted.
7. Standard or "desensitized" (higher inrush, higher rated interrupt) PAF.
8. Environmental concerns – airborne contaminants, excessive heat etc.
9. Mounting orientation – vertical, horizontal, inverted.
10. If an enclosure is ordered, the type and location, of incoming and outgoing connection points.

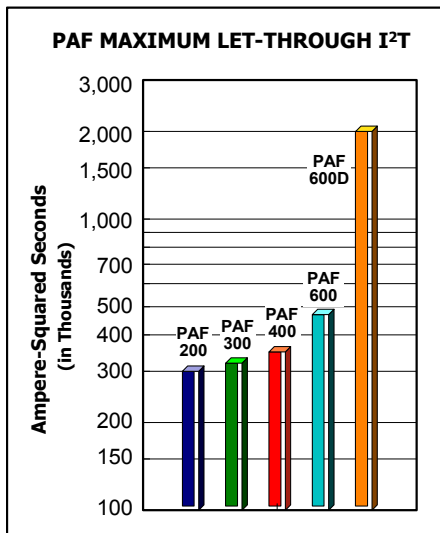

G&W
Engineered to order. Built to last.

G&W Electric Company
305 W. Crossroads Pkwy
Bolingbrook, IL 60440-4938 USA
Tel 708.388.5010 Fax 708.388.0755

www.gwelec.com
ISO 9001:2008 Certified
ISO 14001:2004 Certified

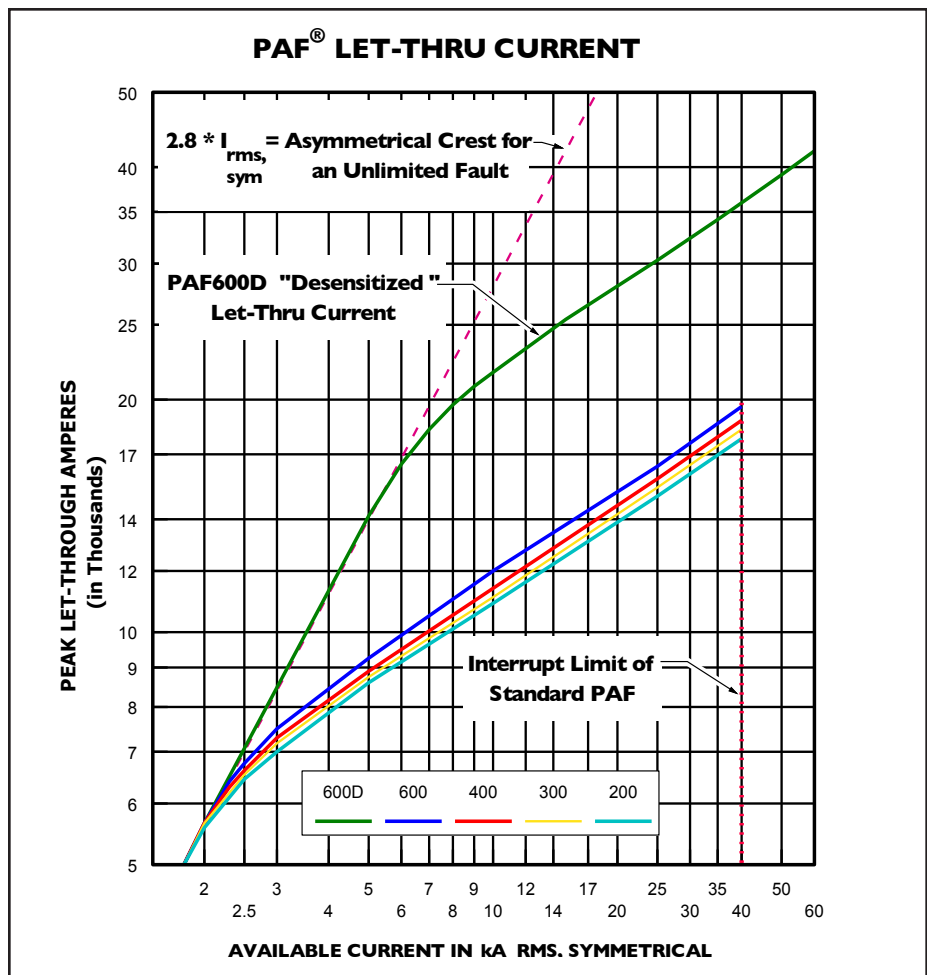

Let-Through Current vs. Prospective Fault Current

The above plot is applicable only for all PAF units. Consult factory Time-Current Characteristic curves.

Or, let us assist you by showing exactly how the PAF will perform in your specific application, as in the example below.

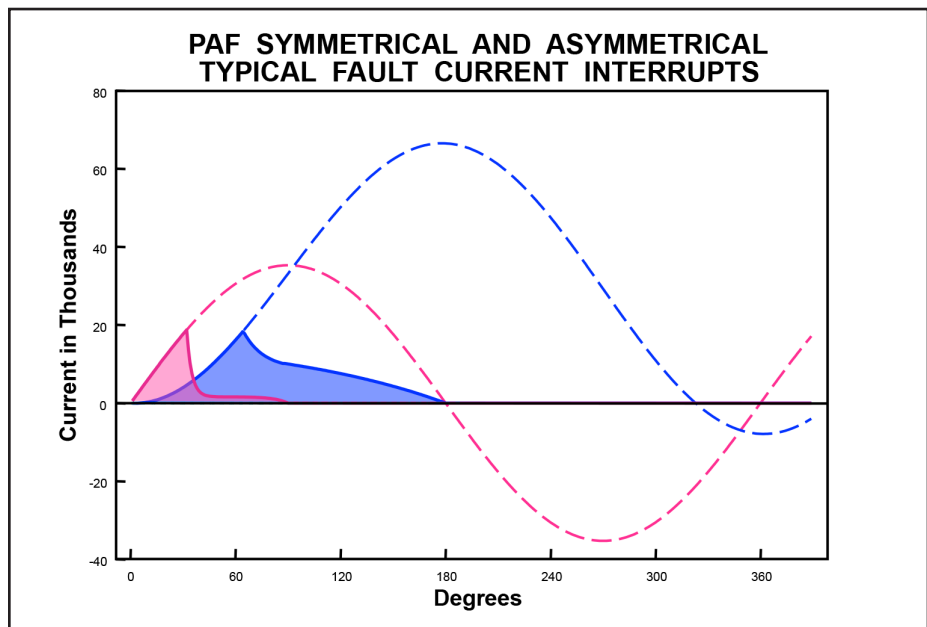

Catalog C-paf17
June, 2017